

1

REV:01

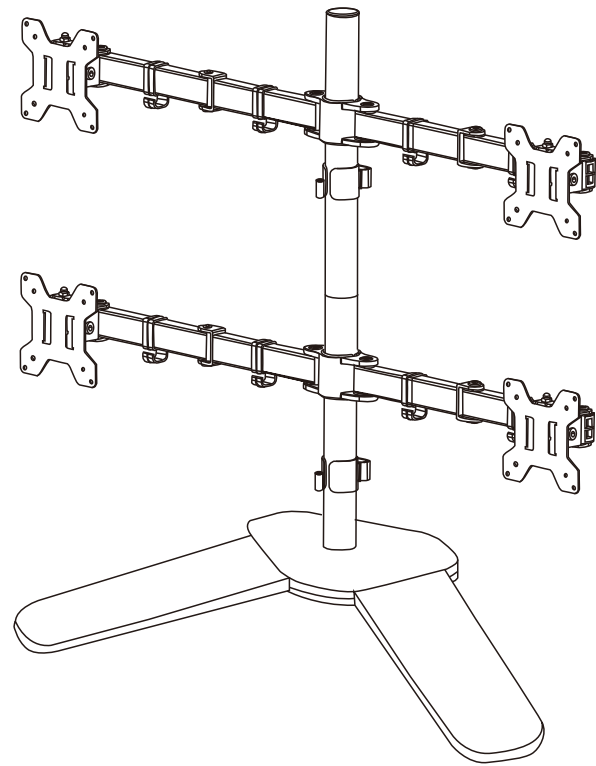

75x75  
100x100

27"  
MAX

7kg  
(15lbs)  
MAX



CAUTION: DO NOT EXCEED  
RATED LISTED WEIGHT. SERIOUS  
INJURY OR PROPERTY DAMAGE  
MAY OCCUR!  
WE DO NOT RESPONSIBLE FOR  
DAMAGES CASUSED BY IMPROPER  
INSTALLATION!

M044

**PART LIST**

	① X1		M6 A X4		I X2
	② X2		M10x16 B X1		J X8
	③ X4		M5x18 C X3		K X1 M8
	④ X2		M6x14 D X5		L X1 M6
	⑤ X1		M4x30 F X16		M X1 M5
	⑥ X1		M4*12 G X16		N X1 M4
	⑦ X1		H X16		O X1 M3
	⑧ X1				
	⑨ X1				

2

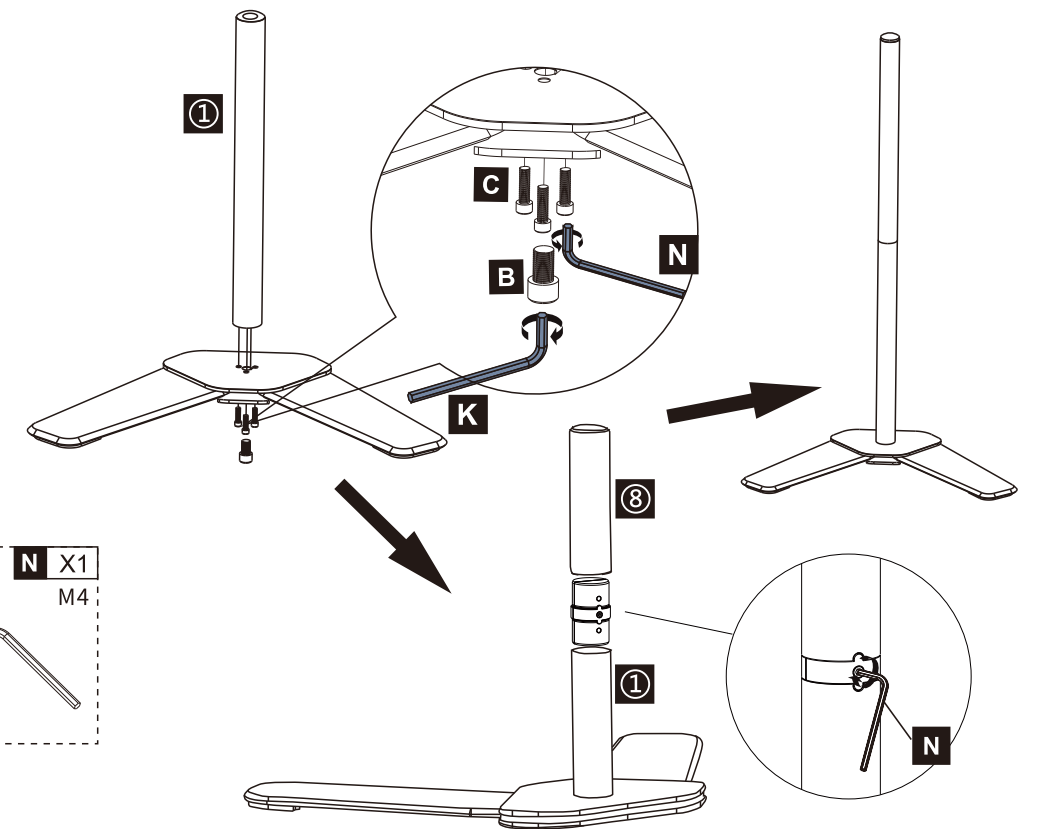
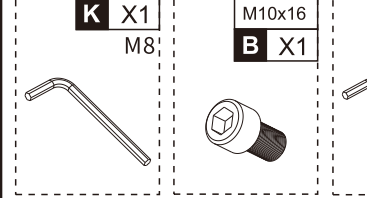
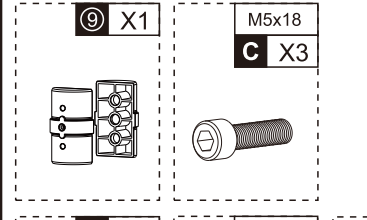
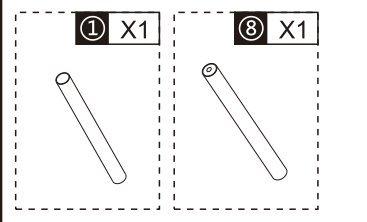
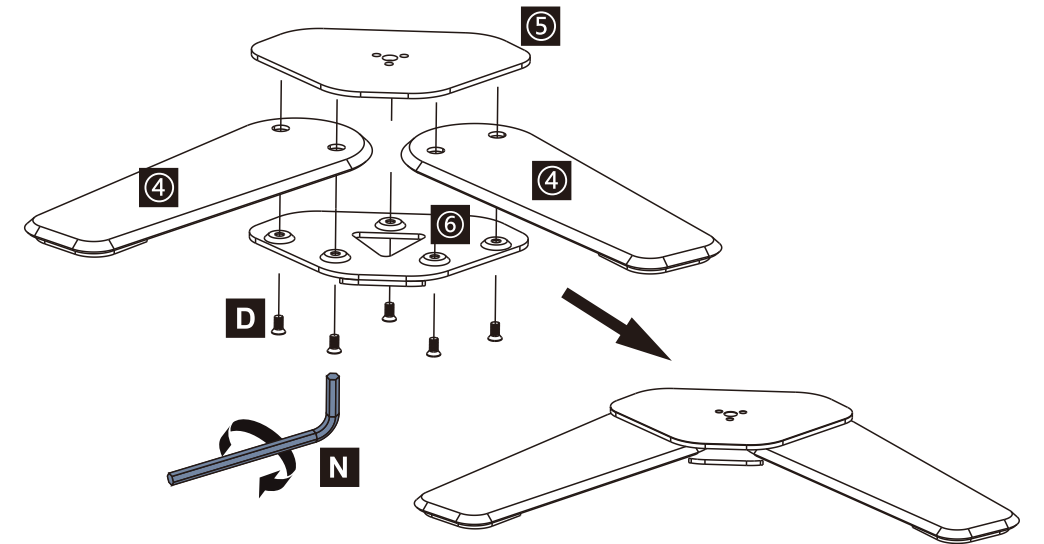
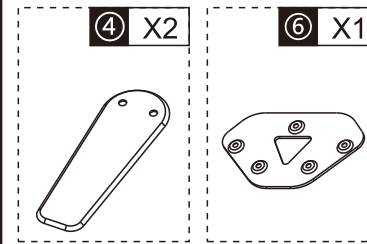
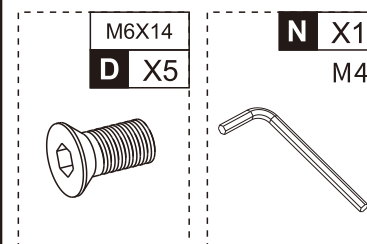
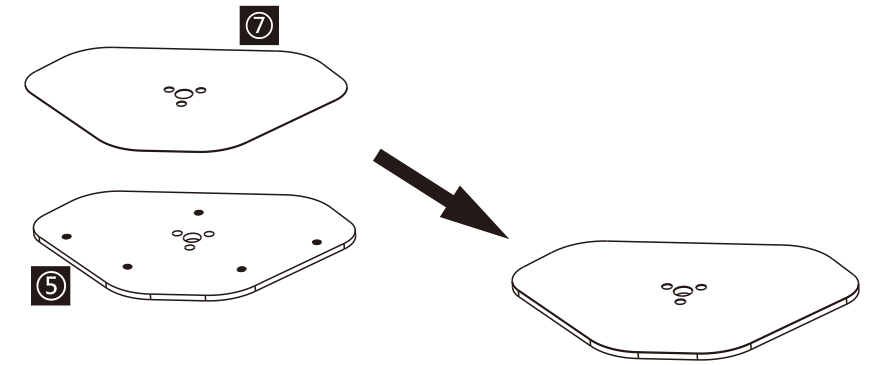
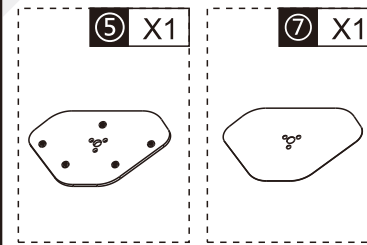

3

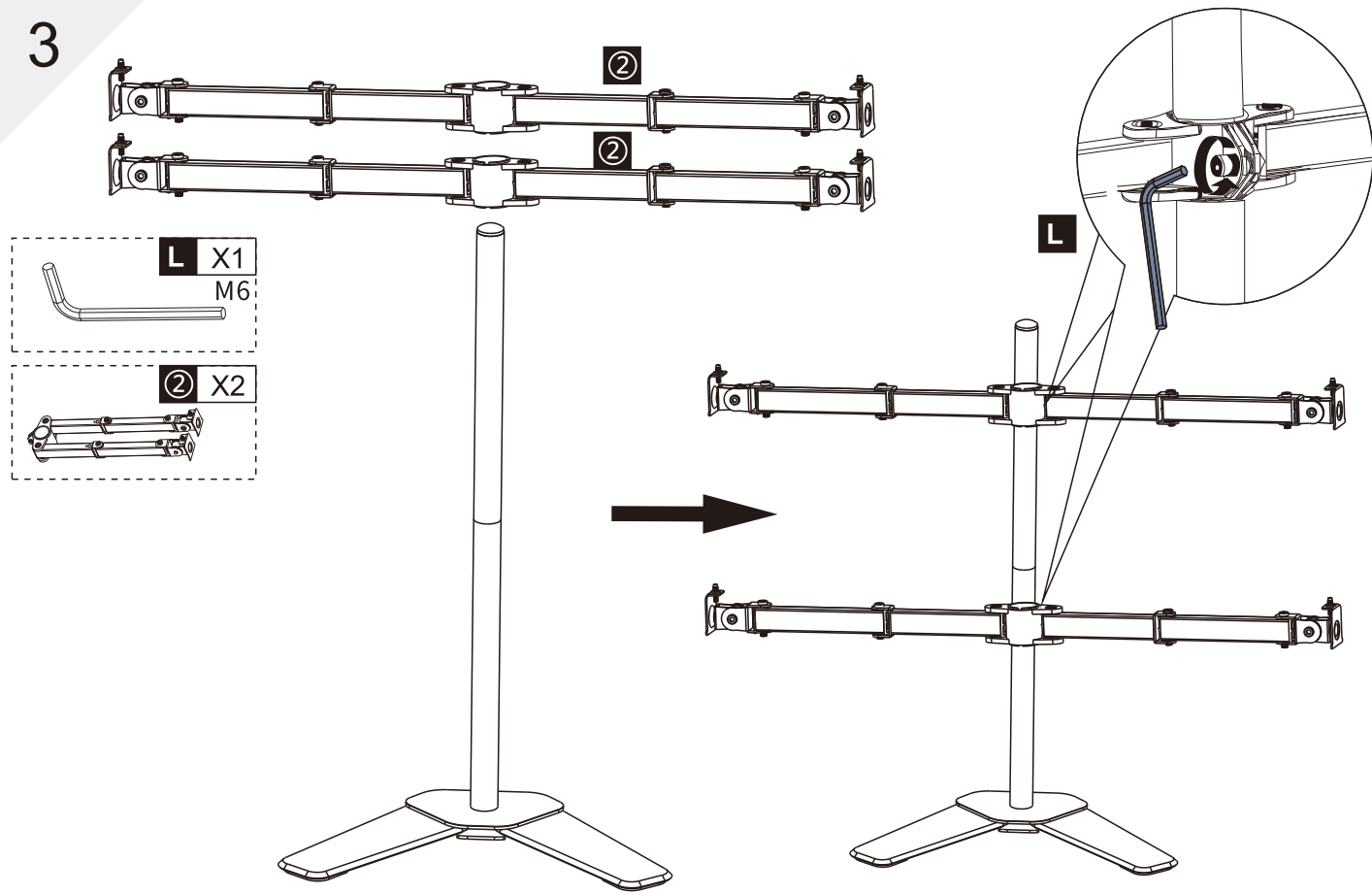

I X2

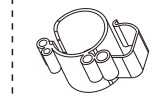

J X8

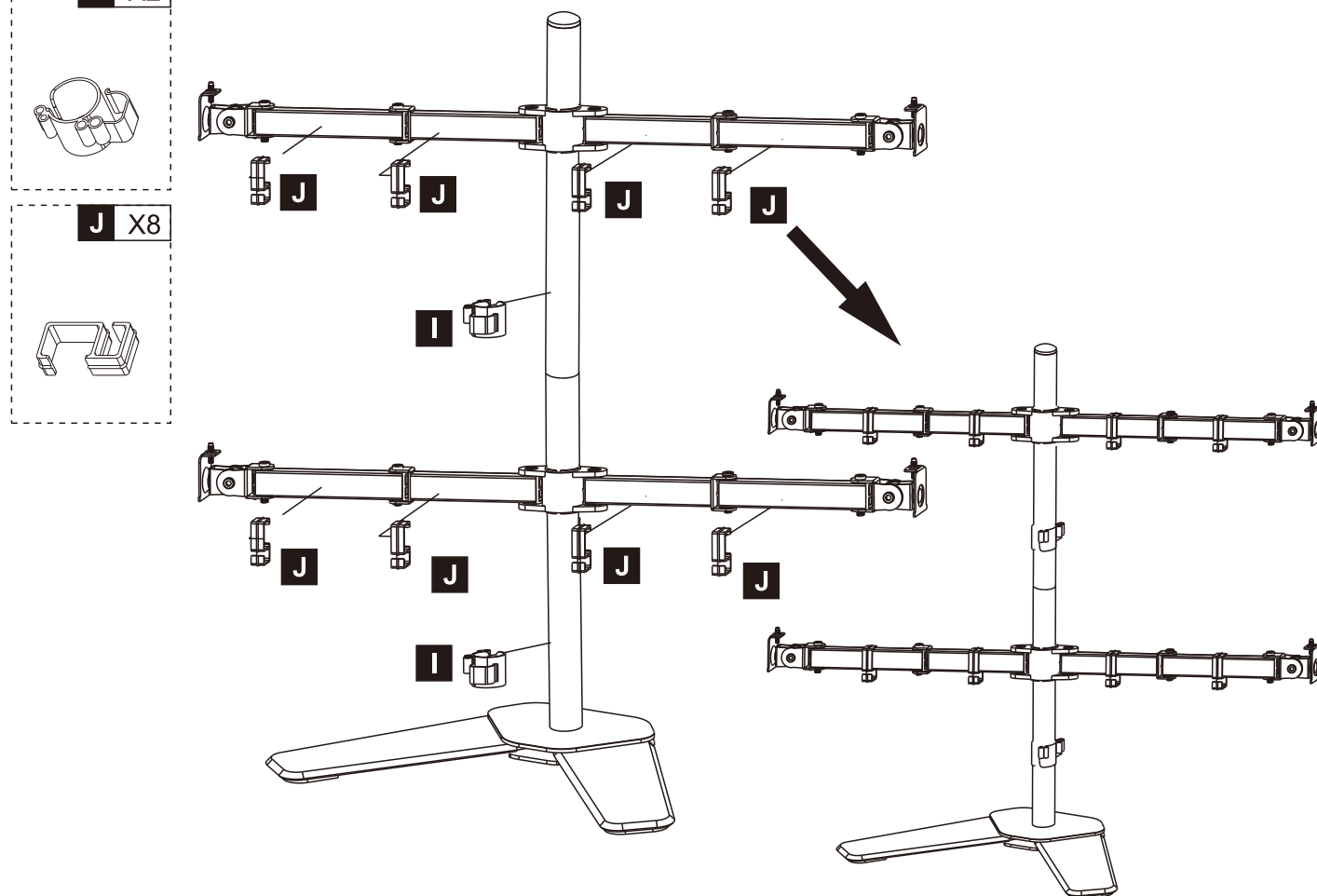
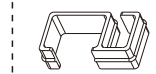

4

- ③ X4
- M4x30  
F X16
- M4\*12  
G X16
- H X16

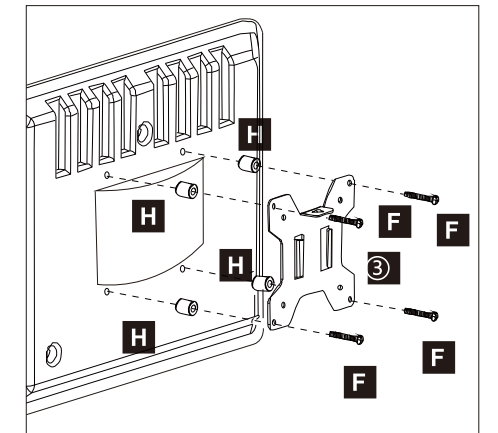
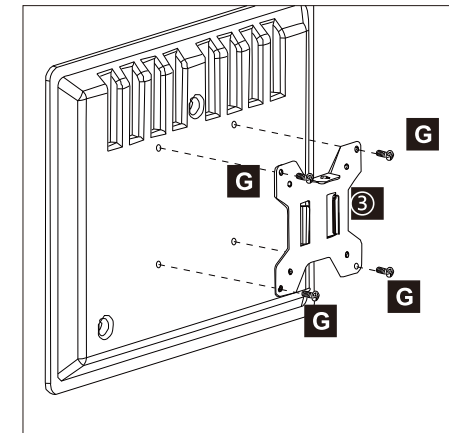

- O X1  
M3
- M6  
A X3

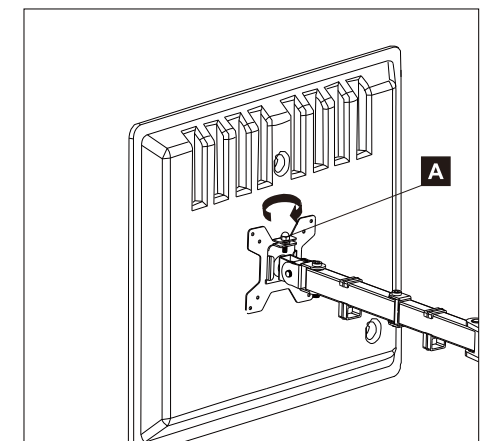
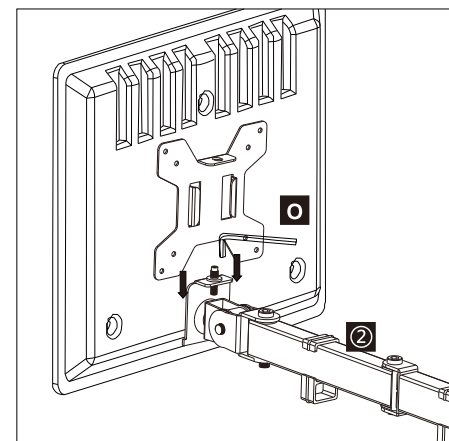

- M X1  
M5

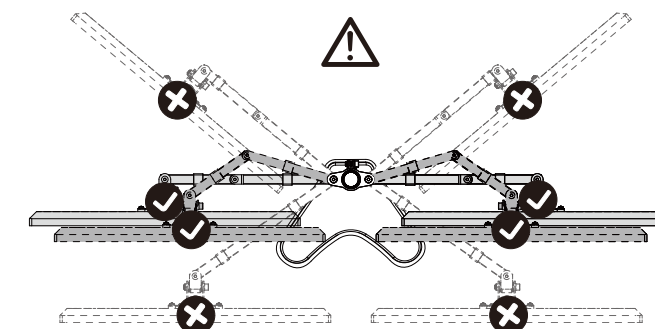
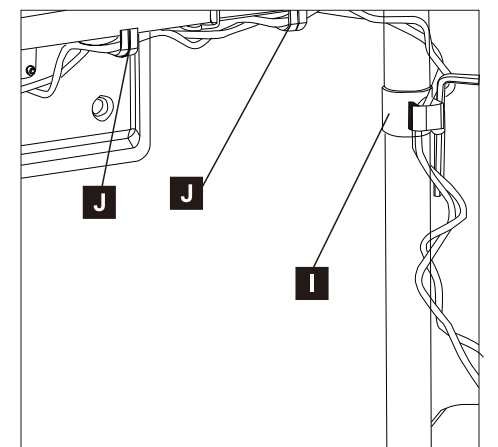
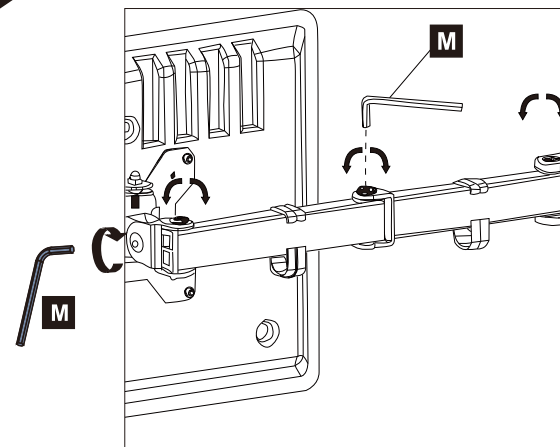

Warning:  
To avoid tipping, please be careful not to extend the arms too far forward or back-ward. When you adjust the angle of the arms, please make sure two arms are balanced to avoid instability of the center of gravity of the base.